

# Eave Lite Square

Cat. No. EAVESQ  
Cat. No. EAVESQGU



The Eave Lite Square is a recessed downlight ideal for installation in eaves, soffits, entrance ways, verandahs, carports or covered decks. It can also be used in bathrooms, kitchens or where moisture transfer or decibel rating is a minimum requirement.

This luminaire is machined from a choice of solid aluminium with a UV stable powder coated finish, solid copper or 316 stainless steel with a clear, tempered, flush glass lens and high temperature silicon gaskets. The 316 stainless steel Eave Lite Square is electro-polished to increase corrosion protection.

A GU10 version of this luminaire is also available for line voltage lamps.

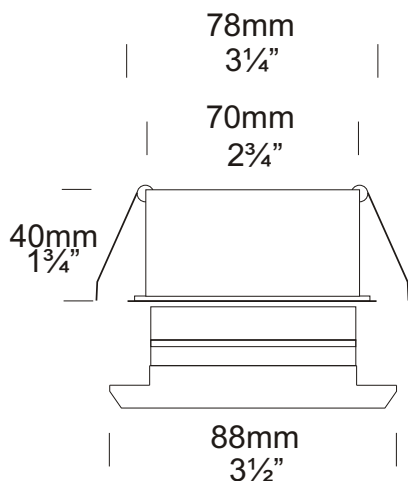

## Ordering Information

Luminaire Type	Material	Accessories
EAVESQ - Eave Lite Square EAVESQGU - Eave Lite Square GU10	BK - Black BZ - Bronze CT - Corten DG - Dark Grey OG - Olive Green STAR - Silver Star WB - White Birch WH - White COP - Copper SS - Stainless Steel	LENSSTEPF - Frosted Lens

Ordering Example: EAVESQ COP - Eave Lite Square in Copper.

EAVESQGU COP - Eave Lite Square GU10 in Copper

LENSSTEPF - Frosted Lens  
(accessories ordered separately)

## Luminaire Construction

**CNC machined from one of the following metals:**

### Aluminium

High corrosion resistant aluminium with chromate substrate and high UV resistant polyester powder coat.

Body: 88mm (3½") x 88mm (3½") solid aluminium rod.

Colours:

Black, Bronze, Corten, Dark Grey, Olive Green, Silver Star, White, White Birch.

### Copper

Body: 88mm (3½") x 88mm (3½") solid copper rod.

### 316 Stainless Steel

Body: electro polished 88mm (3½") x 88mm (3½") solid stainless steel rod.

The electro polish finish increases the protection against corrosion by up to 33%.

### Canister

316 Stainless Steel with two stainless steel spring clips.

## Mounting

Via canister supplied, which maintains the aesthetic look of the flange by eliminating any mounting holes in the flange. The canister is designed to fit through a 70mm hole and be fixed into position by two spring clips. The luminaire is held in the canister by an O ring.

## Features

### Lens

10mm (3/8") clear flush fit shatter resistant glass.  
Lifetime Warranty.

### Gasket

Silicone, iron impregnated 220°C (428°F).

### Lamp Holder

MR16 & GU10 - 350°C (662°F) ceramic multi contact lamp holder with 250°C (480°F) Teflon cables.

## Accessories

**Frosted Lens (Cat. LENSSTEPF).**

## Standards

IP66

## Luminaire Weight

**Aluminium** - 0.400kg (14oz)

**Copper** - 1.000kg (2lb 3oz)

**Stainless Steel** - 0.950kg (2lb 1oz)

## Power Supply

Hunza H20, H40, H50 Transformer: not included.

## Lamp Options

MR16 - 50 watt lamp max.

GU10 - 25 or 35 watt lamp max.

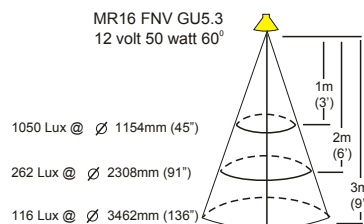
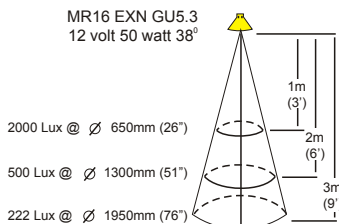
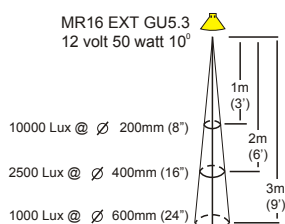
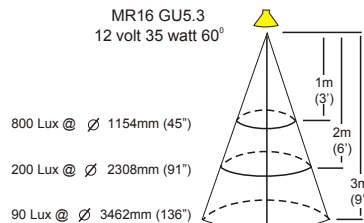
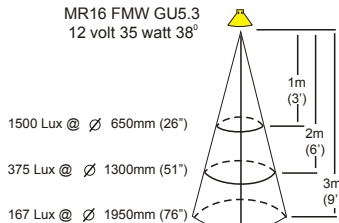
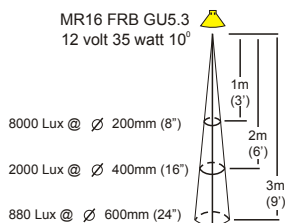
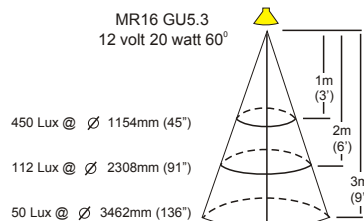
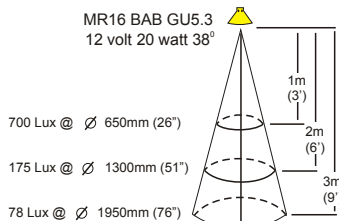
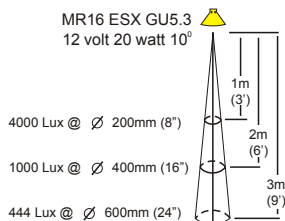

**HUNZA**™ PURE OUTDOOR LIGHTING

HUNZA FACTORY  
130 Felton Mathew Ave  
Glen Innes  
Auckland 1072  
New Zealand

Ph: 64-9-528 9471  
Fax: 64-9-528 9361  
hunza@hunza.co.nz  
www.hunzalighting.com

INTERNATIONAL CONTACTS:  
<http://www.hunzalighting.com/contact.php>  
Specification may change without notice.  
Manufactured in New Zealand.  
© 2016 Hunza Holdings Ltd.