

Floor Lite Square

Cat. No. FLSQ

Cat. No. FLSQGU

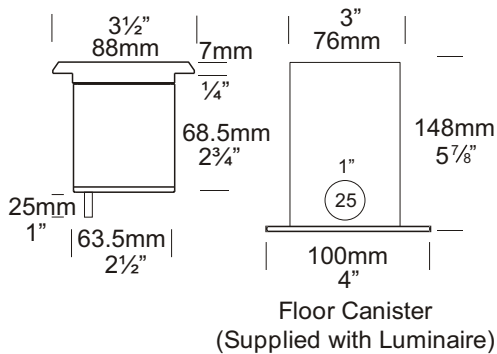

The Floor Lite Square has a 88mm x 88mm (3 1/2" x 3 1/2") flange and has a low profile of 7mm. The square shape makes it ideal for mounting in tiled areas and it can be walked upon without being damaged. There are two flange designs: Louvre (45 degree angle) and Spot and it is supplied with a mounting canister.

A GU10 version of this luminaire is also available for line voltage lamps.



Ordering Information

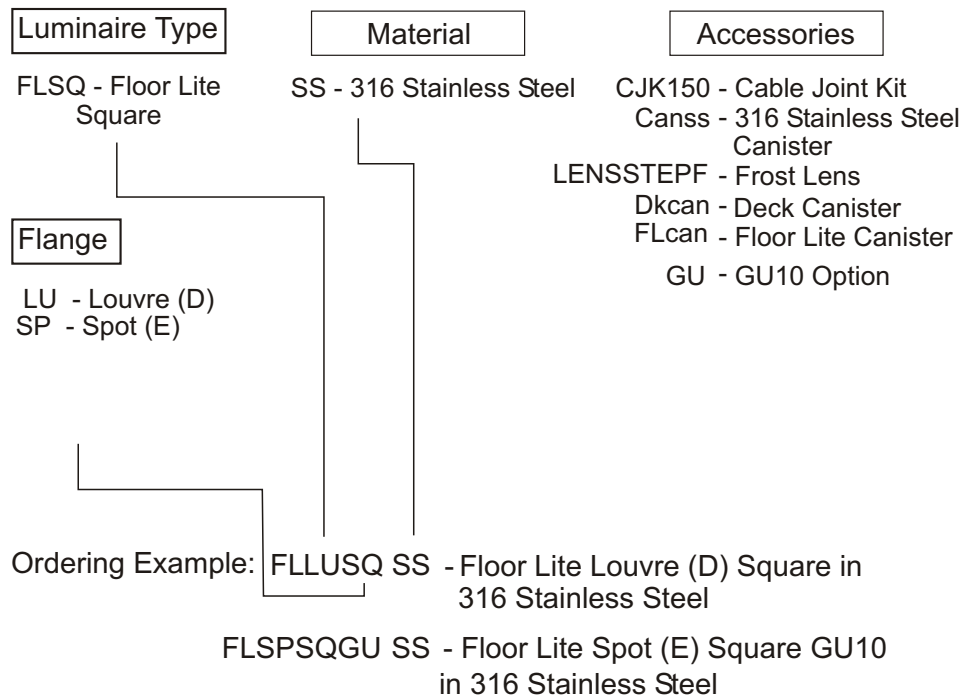

Luminaire Construction

CNC machined from:

Body:

316 Stainless Steel 63.5mm (2½") x 9mm (11/32"). End cap - solid 316 stainless steel 63.5mm (2½") rod.

Flange:

90mm x 90mm (3½" x 3½") solid 316 stainless steel bar.

Mounting

The luminaire is pushed into the canister and is held by two silicone "O" rings: Canss, FLcan, FLucan are cast into concrete, brick, concrete block, etc.

Dkcan: Mounted into wooden decks, wooden frames, etc.

Features

Lens:

3mm (1/8") clear tempered shatter resistant glass.

Lifetime Warranty.

Gasket:

Silicone, iron impregnated 220°C (428°F).

Lamp Holders:

GU5.3 & GU10 - 350°C (662°F) ceramic multi contact lamp holder with 250°C (480°F) teflon cables.

Accessories:

Cable Joint Kit (Cat. CJK150)

Not approved for USA/Canada.

Deck Canister (Cat. Dkcan).

Frosted Lens (Cat. LENSSTEPF).

GU10 Option (Cat. GU).

Hex Cell Louvre Adaptor (Cat. HCL)

(Note: Supplied as standard for USA/Canada).

316 Stainless Canister for use in lime stone etc. (Cat. Canss).

Standards

EN60598

IP66/IP68



UL1838

Luminaire Weight

SS 1.175kg (2lb 9oz)

SS 1.810kg (3lb 15oz)

Power Supply

HUNZA™ Inground or Wall Mount Transformer: not included.

USA and Canada:

HUNZA™ Wall Mount Transformer: not included.

Luminaire: supplied with

MR16 GU5.3 - 20 watt lamp max.

GU10 - GU10 25 or 35 watt lamp max.

USA and Canada:

MR16 GU5.3 20 watt lamp max. GU10 Halogen - Lamp not supplied

MR16 ESX GU5.3
12 volt 20 watt 10°

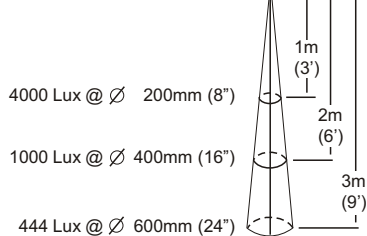

MR16 BAB GU5.3
12 volt 20 watt 38°

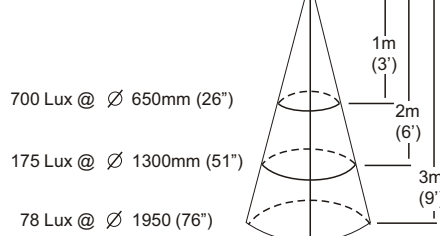

MR16 GU5.3
12 volt 20 watt 60°

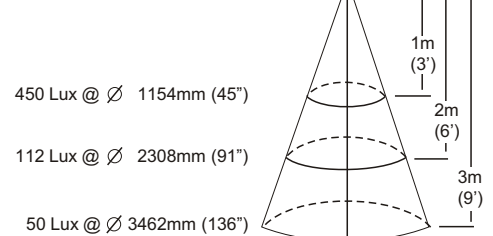

These diagrams refer to the Spot Lite Flange (E) only.