

# Flush Floor Lite Square

Cat. No. FFLSPSQ  
 Cat. No. FFLSPSQGU

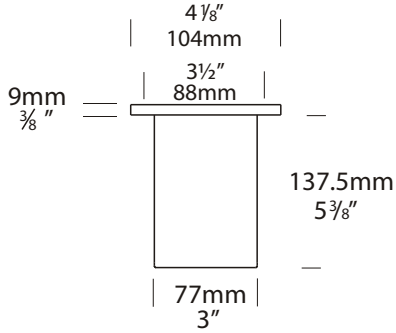

Flush Floor Lite Square



The Flush Floor Lite Square has been designed to mount flush with the level of a pathway, hotel floor or a building foyer. The 'Flush Fit' lens stops water pooling and depositing dirt on the lens. There is no lip to trip over and the luminaire can be driven over or walked upon without being damaged. The canister is included for easy installation.

The square shape of The Flush Floor Lite Square makes it ideal for mounting in tiled areas.

## Ordering Information

Luminaire Type	Material	Accessories
FFLSPSQ - Flush Floor Lite Square	SS - 316 Stainless Steel	CJK150 - Cable Joint Kit HCL - Hex Cell Adaptor LENS SPREAD - Linear Spread Lens LENSSTEPF - Frost Lens

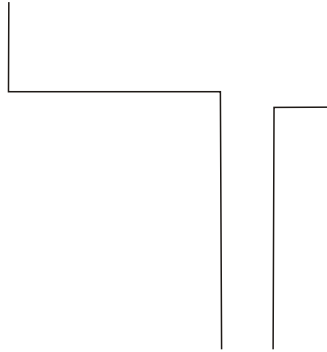

Ordering Example: FFLSPSQ SS - Flush Floor Lite in 316 Stainless Steel

## Luminaire Construction

CNC machined from:

Body:

316 Stainless Steel 63.5mm (2½") x 9mm (11/32").

End Cap - 316 Stainless Steel 63.5mm (2½") rod.

Canister:

Stainless Steel: 316 Stainless Steel Canister 148.5mm (5½") x 1mm (3/64").

Flange:

316 Stainless Steel or Copper 104mm (4 1/8").

Flange Square:

316 Stainless Steel or Copper 110mm (4¾") x 110mm (4¾").

## Mounting

The luminaire is pushed into the canister and is held by one silicone "O" ring: Cast into concrete, brick, concrete block etc.

Maximum drive over speed 10 km/h (6 mph) and maximum vehicle weight 1500kg (3300lbs).

## Features

Lens:

10mm (3/8") thick 'Flush Fit' clear tempered shatter resistant glass.

Lifetime Warranty.

Gasket:

Silicone, iron impregnated 220 °c (428 °f).

Lamp Holders:

GU5.3 & GU10 - 350°C (662°F) ceramic multi contact lamp holder with 250°C (480°F) teflon cables.

Accessories:

Cable Joint Kit (Cat. CJK150).

Frosted Lens (Cat. LENSSTEPF).

Hex Cell Louvre Adaptor (Cat. HCL)

(Note: Supplied as standard for USA/Canada).

GU10 Option (Cat. GU).

## Standards

EN60598

IP67



UL1838

## Luminaire Weight

SS 1.50kg (3lb 5oz)

COP 1.70kg (3lb 12oz)

## Power Supply

HUNZA™ Inground or Wall Mount Transformer: not included.

## USA and Canada:

HUNZA™ Wall Mount Transformer: not included.

## Luminaire: supplied with

MR16 GU5.3 - 20 watt lamp max.

GU10 - GU10 25 or 35 watt lamp max.

## USA and Canada:

MR16 GU5.3 20 watt lamp max.

GU10 Halogen - Lamp not supplied

MR16 ESX GU5.3  
12 volt 20 watt 10 °

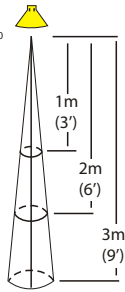

MR16 BAB GU5.3  
12 volt 20 watt 38 °

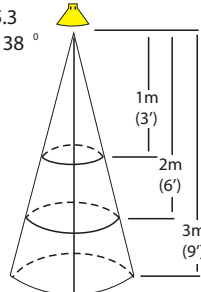

MR16 GU5.3  
12 volt 20 watt 60 °

