

# Wall Down Lite

Cat. No. DL  
Cat. No. DL/R

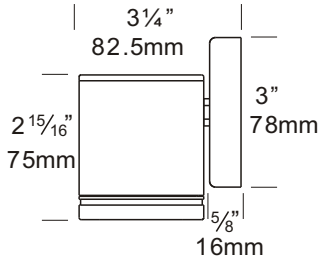

The Wall Down Lite is suitable for mounting on timber, masonry, stone, etc. non-adjustable for one way wall washing, can be mounted with the lamp directed up or down. Water resistant with a 78mm diameter mounting base, complete with stainless steel screws.

The Retro™ is a 110/240-12 ac mains option suited to an installation where mounting a transformer is a problem, e.g. a brick wall where there is only the cable protruding out of the wall and it is not an option to recess the transformer or when replacing an existing light fitting. The base size increases in size to accommodate the encapsulated IP66 dimmable transformer.

## Ordering Information

| Luminaire Type      | Material/Finish   | Accessories  |
|---------------------|---|--|
| DL - Wall Down Lite | BK - Black<br>BZ - Bronze<br>GN - Green<br>STAR - Silver Star<br>WH - White<br>COP - Copper<br>SS - 316 Stainless Steel | CJK150 - Cable Joint Kit<br>LENSSTEPF - Frosted Lens<br>GG - Glare Guard<br>HCL - Hex Cell Louvre Adaptor<br>/R - Retro™ Transformer<br>110/240-12 volt<br>WBAP - Wall Box Adaptor Plate<br>For an LED option refer to page 10.4 onwards |
| Retro™              |   |  |
| Retro™ USA/Canada   |   |  |

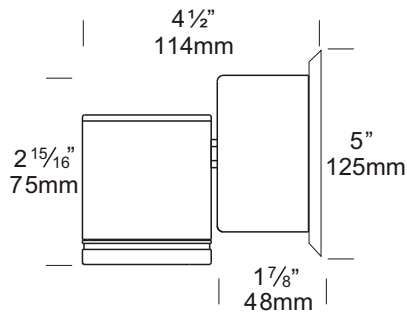
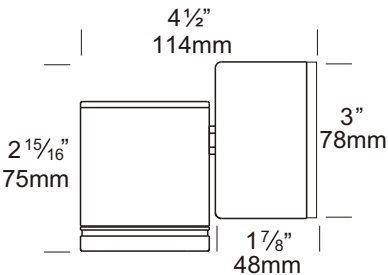

Ordering Example: DL BK - Wall Down Lite in Black  
DL/R SS - Wall Down Lite Retro™ in 316 Stainless Steel  
LENSSTEPF - Frosted Lens  
(Accessories ordered separately)

**HUNZA**™ PURE OUTDOOR LIGHTING

**HUNZA FACTORY**  
130 Felton Mathew Ave  
Glen Innes  
Auckland 1072  
New Zealand

Ph: 64-9-528 9471  
Fax: 64-9-528 9361  
hunza@hunza.co.nz  
www.hunza.co.nz

**INTERNATIONAL CONTACTS:**  
www.hunza.co.nz/contacts.php  
Specifications may change without notice.  
Manufactured in New Zealand.  
© 2009 Hunza Holdings Ltd.

## Luminaire Construction

CNC machined from the following metals:

**Body:** High corrosion resistant low copper 63.5mm (2½") x 10mm (25/64") aluminium. End cap - solid aluminium 63.5mm (2½") rod.

**Base & Mounting Plate (Retro™):** Cast from virgin high corrosion resistant CC401 low copper aluminium alloy chromate substrate and high UV resistant polyester powder coat - Black, Bronze, Green, Silver Star, White.

**Body:** Copper 63.5mm (2½") x 10mm (25/64). End cap - solid copper 63.5mm (2½") rod.

**Base:** Copper Hand spun 2mm (5/64")

**Mounting Plate:** Forged brass (Retro™)

**Body:** 316 Stainless Steel 63.5mm (2½") x 10mm (25/64) rod. End cap - 316 stainless steel 63.5mm (2½") rod.

**Base:** Investment cast and CNC machined (Retro™).

**Mounting Plate:** Investment cast and CNC machined.

## Mounting

12 volt: the luminaire is mounted to the wall using two 316 stainless screws through a shallow base 16mm (5/8") in depth. A Wall Box Adaptor Plate is available as an accessory to fit 3.0 and 4.0 junction boxes for USA/Canada.

Retro™ 110/240-12 volt: a mounting plate is fixed to the wall using two screws, the luminaire is fitted to the mounting plate.

## Features

Lens:

10mm (3/8") clear flush fit shatter resistant glass.

Life Time Warranty.

Gasket:

Silicone, iron impregnated 220°C (428°F).

Lamp Holder:

GU5.3 - 350°C (662°F) ceramic multi contact lamp holder with 250°C (480°F) teflon cables.

Accessories:

Cable Joint Kit (Cat. CJK150)

Not approved for USA/Canada.

Frosted Lens (Cat. LENSSTEPF).

Glare Guard (Cat. GG).

Hex Cell Louvre Adaptor (Cat. HCL).

Retro™ transformer 110/240-12 volt (Cat. /R).

Wall Box Adaptor Plate (Cat. WBAP 12 volt luminaire USA / Canada).

## Standards

IP66  UL1838

Luminaire Weight

12 volt: Alum .460kg (1lb)  
Cop 1.200kg (2lb 10oz)  
SS 1.080kg (2lb 6oz)  
Retro: Alum .780kg (1lb 11oz)  
Cop 1.680kg (3lb 11oz)  
SS 1.505kg (3lb 5oz)

## Power Supply

HUNZA™ Inground or Wall Mount  
Transformer: not included.

USA and Canada:

HUNZA™ Wall Mount: not included  
Approved for internal use.

RETRO™

HUNZA™ 110/240-12 volt ac  
potted electronic transformer built  
into the Retro™ base. Dimmable with a  
suitable dimmer.

Approved for internal use.

Luminaire: supplied with

MR16 GU5.3 20, 35 or 50 watt lamp max.

**LED** - Refer sheet no. 10.4

**GU10** - Refer sheet no. 10.9

USA and Canada:

MR16 GU5.3 20 or 35 watt lamp.

**LED** - Refer sheet no. 10.4

**GU10** - Refer sheet no. 10.9

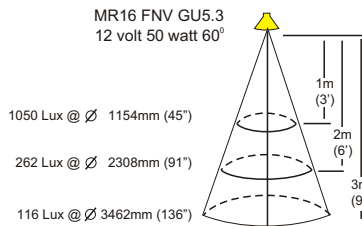
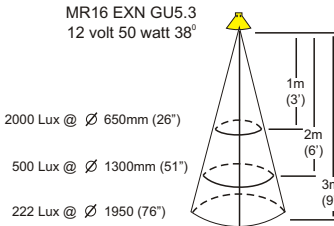
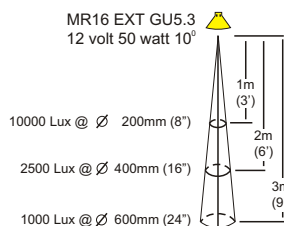
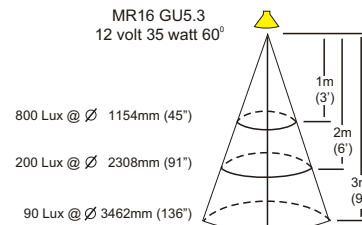
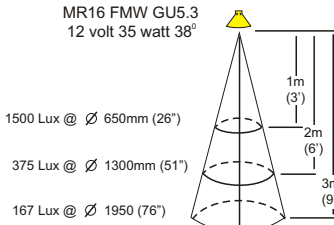
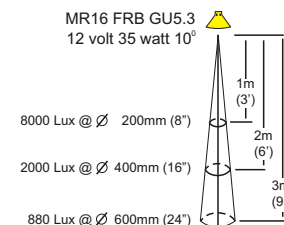
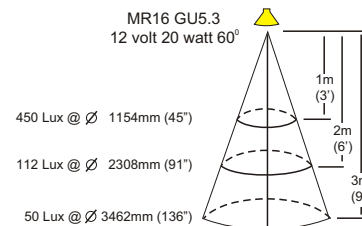
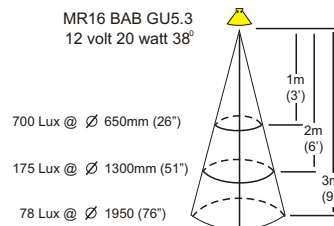
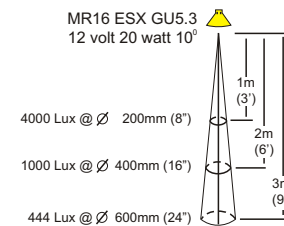

**HUNZA™** PURE  
OUTDOOR  
LIGHTING

**HUNZA FACTORY**  
130 Felton Mathew Ave  
Glen Innes  
Auckland 1072  
New Zealand

Ph: 64-9-528 9471  
Fax: 64-9-528 9361  
hunza@hunza.co.nz  
www.hunza.co.nz

**INTERNATIONAL CONTACTS:**  
www.hunza.co.nz/contacts.php

Specifications may change without notice.  
Manufactured in New Zealand.

© 2009 Hunza Holdings Ltd.

Ver 1.4