

Ultra 35 Liquid Beam™ Wall Spot Light - RGBW

INTELLIGENT LUMINAIRE

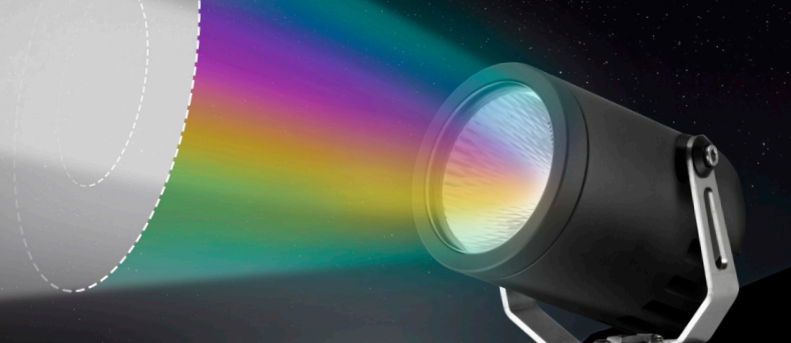

SPECIFICATIONS



LED Chip	LED ENGINE LZ4 RGBW
Luminaire Output	400 total Lumens all colours on, delivered from the Luminaire with unobstructed beam
Lumens Per Watt	30 Lumens minimum @ 13 watts, delivered from Luminaire with unobstructed beam
CRI (5400K)	RGBW (White 75)
Colour Temperatures	RGBW (White CCT 5400)
Beam Angles	Liquid Beam™ Technology Solid State Control 10 to 50 Deg
Ingress Protection	IP66

Warranty	Electronics = 5 years Body Aluminium = 5 years
Standards	BS/EN 60598.2.2 cUL 1598, CSA C22.2 No. 250.0 CE

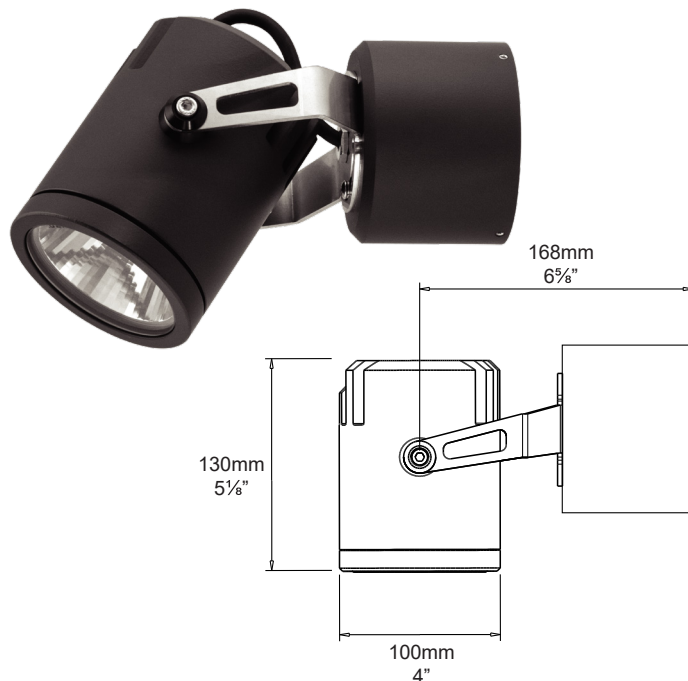

CASAMBI +

Smart Lighting Bluetooth Ecosystem

Liquid Beam™

A Solid State Light Beam controlled via Bluetooth, adjustable between 10-50 degrees. No need to service the fixture to adjust the beam.

PRODUCT CONFIGURATION

Please fill in appropriate codes into boxes provided

Cat. No. WS/U35/LBRGBW

Luminaire	Power	Material/ Finish	Accessories
WS/U35/LBRGBW	<input type="text"/>	<input type="text"/>	<input type="text"/> - <input type="text"/> - <input type="text"/> - <input type="text"/> - <input type="text"/>
R RETRO, 85-640V DRIVER D24 24V DC Input RETRO, 85-264VAC INPUT: Constant voltage driver (included) Input: 84-264 volts Output: 13 watts 24VDC DRIVER: Input: 24vdc Load up to 0.55 Amps Use appropriate 24VDC Driver	ALUMINIUM EBK BLACK EBZ BRONZE EOGR OLIVE GREEN EWH WHITE EWB WHITE BIRCH EDG DARK GREY ESTAR SILVER STAR ECT CORTEN	CJK CABLE JOINT KIT ULT35GG GLARE GUARD HCL/U35 HEX CELL LOUVRE ULT35SNT SNOOT PB/U35 POLE BRACKET ULT35SNT SNOOT ULT35WP WALL PLATE	

ADDITIONAL COMMENTS:

Full hue spectrum & colour temperature control with Casambi. Bluetooth Mesh enabled via CASAMBI (free to download Lighting Control App) 10-50 Degree beam angle control with Liquid Beam™ Solid State Control. No external control gear required.

LUMINAIRE CONSTRUCTION

CNC machined from one of the following metals:

Aluminium:

Base: 101mm (4") solid aluminium rod
 Body: 101mm (4") high corrosion resistant aluminium rod with chromate substrate and high UV resistant polyester powder coat.
 Colours: Black, Bronze, Silver Star, White, White Birch, Olive Green, Dark Grey, Corten.

316 Stainless Steel:

Bracket: laser cut and folded 316 stainless steel.

Adjustability:

The fully adjustable head allows 360 degree rotation and 0-120 degree elevation.

Cable:

Water resistant rubber.

Gaskets:

Silicone, iron impregnated 220°C (428°F).

Step Lens:

12mm (1/2") extra clear, low iron, shatter resistant glass.
 Lifetime warranty.

Mounting:

The mounting plate is fixed to the surface using three stainless steel screws. The luminaire is then fixed to the mounting plate. A large Wall Plate is available for mounting over junction boxes.

Luminaire Weight:

4kg (9lb)

ACCESSORIES

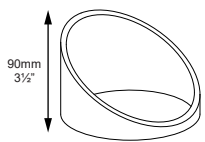

Glare Guard

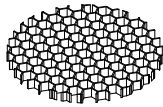

Hex Cell Louvre

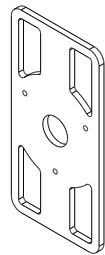

Pole Bracket

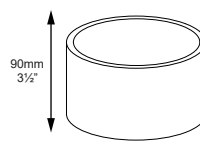

Snoot

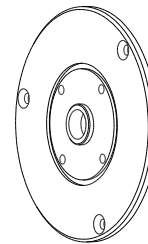

Wall Plate
127mm (5")

BEAM ANGLES: Controlled with Liquid Beam™ Technology

Solid State Beam control Via Bluetooth Casambi App

IES files available for download: <http://www.hunzalighting.com/download.php>

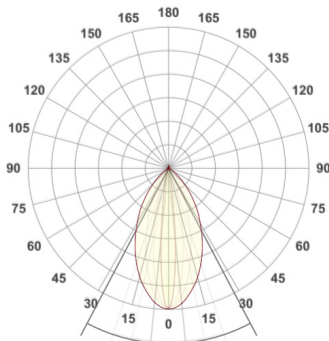

Adjustable between 10° to 50°

WIRING GUIDE

Available for download: www.hunzalighting.com/download.php

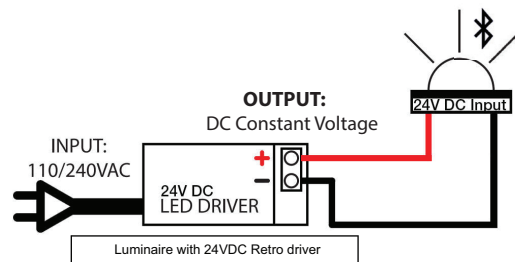
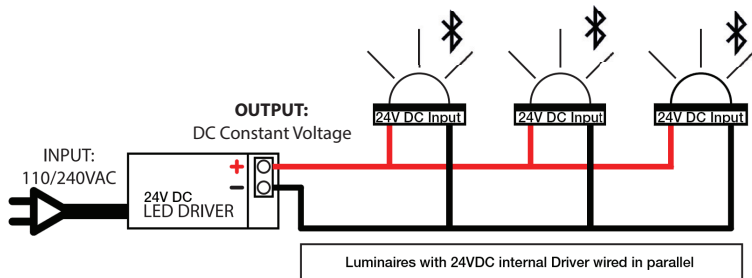

Try CASAMBI Smart Light Demo
 Free to Download on IOS or Android



Specifications may change without notification

Oct 2021 V1